

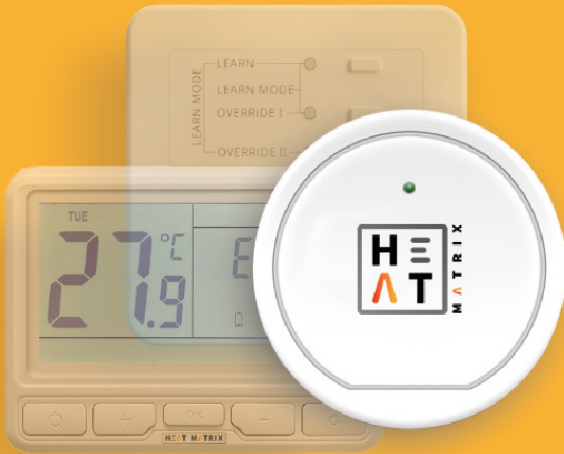

WIFI GATEWAY MODULE HM28HUB10



-  WIRELESS CONNECTIVITY
-  THERMOSTAT COMPATIBLE
-  2 CHANNEL DEVICE
-  SMART HOME INTEGRATION

DESCRIPTION

The receiver and thermostat working alongside the HUB10, make for wireless control of high powered heating equipment such as electric heaters. It can also control low power AC devices like electric actuators. By connecting to the internet through the HUB10, the temperature controller HM26RF can be programmed and adjusted to your desired temperature remotely by using the app on your iOS or Android smartphone. Without HUB10, the thermostat and receiver still operate as a high performance energy-saving wireless control set.

This unit comes with a 1 year warranty.

DIMENSIONS (WIFI HUB)

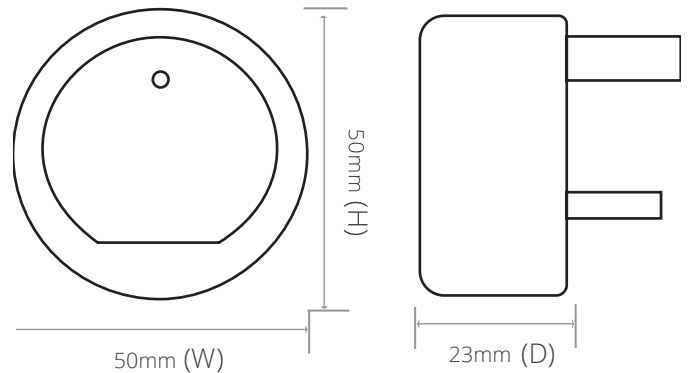

HUB10 CONFIGURATION

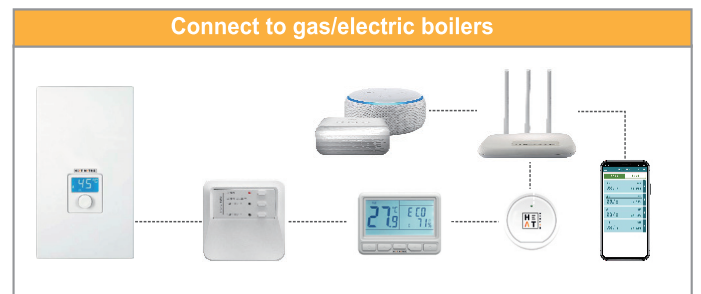
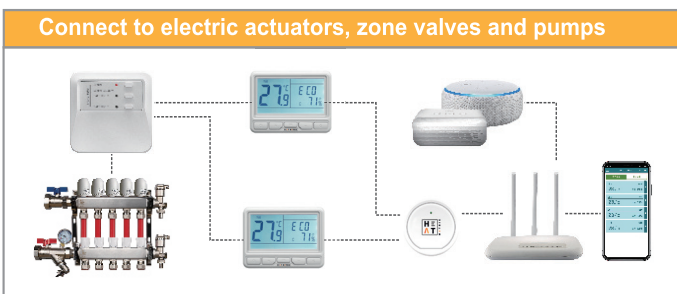

TECHNICAL DATA

| MODELS | OPERATING TEMP | SWITCH RATING | POWER | DIMENSIONS (mm) | | | COMMUNICATION RANGE | TRANSMITTING FREQUENCY |
|----------|----------------|---------------|-----------------|-----------------|-----|----|---------------------|---|
| | | | | H | W | D | | |
| HM26RF | 0~50°C | | 2x AA Batteries | 85 | 115 | 28 | 100m | 868MHz 433MHz for option, Bidirectional |
| HM26RF5 | 0~50°C | 5A | 2W | 95 | 95 | 28 | 100m | |
| HM26RF16 | 0~50°C | 16A | <2W | 95 | 95 | 28 | 100m | |
| HUB10 | 0~50°C | | 1.5W | 50 | 50 | 23 | 100m | |

